



# Product Specification

M190ETN01.0

AU OPTRONICS CORPORATION

( ) Preliminary Specification

( V ) Final Specification

<b>Module</b>	19.0" Color TFT-LCD
<b>Model Name</b>	M190ETN01.0

Customer	Date
_____	_____
<b>Approved by</b>	
_____	_____
Note: This Specification is subject to change without notice.	

Approved by	Date
<u>Howard Lee</u>	<u>Oct. 23, 2012</u>
<b>Prepared by</b>	
<u>Vincent Chan</u>	<u>Oct. 23, 2012</u>
AU Optronics Corporation	

## Content

<b>1 HANDLING PRECAUTIONS .....</b>	<b>5</b>
<b>2 GENERAL DESCRIPTION.....</b>	<b>6</b>
2.1 Display Characteristics.....	6
2.2 Optical Characteristics.....	7
2.3 Mechanical Characteristics.....	11
<b>3 FUNCTIONAL BLOCK DIAGRAM.....</b>	<b>12</b>
<b>4 ABSOLUTE MAXIMUM RATINGS .....</b>	<b>13</b>
4.1 TFT LCD Module .....	13
4.2 Backlight Unit.....	13
4.3 Absolute Ratings of Environment .....	13
<b>5 ELECTRICAL CHARACTERISTICS .....</b>	<b>15</b>
5.1 TFT LCD Module .....	15
5.1.1 Power Specification .....	15
5.1.2 Signal Electrical Characteristics.....	17
5.2 Backlight Unit.....	19
<b>6 SIGNAL CHARACTERISTICS .....</b>	<b>20</b>
6.1 Pixel Format Definition.....	20
6.2 Input Data Format Definition.....	20
6.3 Signal Description.....	21
6.4 Timing Characteristics.....	23
6.5 Timing Diagram .....	24
6.6 Power ON/OFF Sequence .....	25
<b>7 CONNECTOR AND PIN ASSIGNMENT.....</b>	<b>26</b>
7.1 TFT LCD Module .....	26
7.1.1 Pin Assignment.....	26
7.2 LED Connector on Backlight Unit.....	27
7.2.1 LED Pin assignment.....	27
7.2.2 LED Connector Dimension.....	28
7.2.3 LED Mating housing dimension.....	28
<b>8 RELIABILITY TEST .....</b>	<b>29</b>
<b>9 SHIPPING LABEL.....</b>	<b>31</b>
<b>10 MECHANICAL CHARACTERISTICS .....</b>	<b>32</b>
<b>11 PACKING SPECIFICATION .....</b>	<b>33</b>
11.1 Packing Flow.....	33
11.2 Pallet and Shipment Information .....	34

## Records of Revision

Version and Date	Page	Old description	New Description	Remark																																																																																																																																									
0.1 2012/06/21	All	Frist Edition for Customer																																																																																																																																											
0.2 2012/08/03	30		Add screw torque value.																																																																																																																																										
0.3 2012/08/07	13	4.1 TFT LCD Module: Logic/LCD Drive Voltage : Min 0V	4.1 TFT LCD Module: Logic/LCD Drive Voltage : Min -0.3V																																																																																																																																										
	6	2.1Display Characteristics / Power Consumption / 11.38 watt VDD line : PDD (typ), All black pattern at 60Hz =3.05W LED line : PBLU (typ) = 8.33W	2.1Display Characteristics / Power Consumption / 11.03 watt VDD line : PDD (typ), All black pattern at 60Hz =2.7W LED line : PBLU (typ) = 8.33W																																																																																																																																										
	28	8.Reliability Test/Altitude Test : Operation:10,000 ft Non-Operation:30,000 ft	8.Reliability Test/Altitude Test : Operation:18,000 ft Non-Operation:40,000 ft																																																																																																																																										
1.0 2012/10/03	6	Power Consumption / LED line : PBLU (typ) = 8.33W	Power Consumption / LED line : PBLU (typ) = 8.45W																																																																																																																																										
	13	4.2 Backlight unit : LED forward Voltage variation (per string variation) : 3.4V	4.2 Backlight unit : LED forward Voltage variation (per string variation) : 2.2																																																																																																																																										
	12	I/F PCB Interface: 187034-30091 / FI-XB30SSLA-HF15 (P-TWO) FI-XB30SSLA-HF15 (JAE)	Delete interface statement.																																																																																																																																										
	22	6.4 EE Timing: <table border="1"> <thead> <tr> <th>Signal<sup>o</sup></th> <th>Item<sup>o</sup></th> <th>Symbol<sup>o</sup></th> <th>Min<sup>o</sup></th> <th>Typ<sup>o</sup></th> <th>Max<sup>o</sup></th> <th>Unit<sup>o</sup></th> </tr> </thead> <tbody> <tr> <td rowspan="3">Vertical Section<sup>o</sup></td> <td>Period<sup>o</sup></td> <td>T<sub>v</sub><sup>o</sup></td> <td>1032<sup>o</sup></td> <td>1066<sup>o</sup></td> <td>1186<sup>o</sup></td> <td>Th<sup>o</sup></td> </tr> <tr> <td>Active<sup>o</sup></td> <td>T<sub>disp(v)</sub><sup>o</sup></td> <td>1024<sup>o</sup></td> <td>1024<sup>o</sup></td> <td>1024<sup>o</sup></td> <td>Th<sup>o</sup></td> </tr> <tr> <td>Blanking<sup>o</sup></td> <td>T<sub>bp(v)+T<sub>ip(v)+PW<sub>vs</sub></sub><sup>o</sup></sub></td> <td>8<sup>o</sup></td> <td>42<sup>o</sup></td> <td>126<sup>o</sup></td> <td>Th<sup>o</sup></td> </tr> <tr> <td rowspan="3">Horizontal Section<sup>o</sup></td> <td>Period<sup>o</sup></td> <td>T<sub>h</sub><sup>o</sup></td> <td>780<sup>o</sup></td> <td>844<sup>o</sup></td> <td>2047<sup>o</sup></td> <td>Tclk<sup>o</sup></td> </tr> <tr> <td>Active<sup>o</sup></td> <td>T<sub>disp(h)</sub><sup>o</sup></td> <td>640<sup>o</sup></td> <td>640<sup>o</sup></td> <td>640<sup>o</sup></td> <td>Tclk<sup>o</sup></td> </tr> <tr> <td>Blanking<sup>o</sup></td> <td>T<sub>bp(h)+T<sub>ip(h)+PW<sub>vs</sub></sub><sup>o</sup></sub></td> <td>140<sup>o</sup></td> <td>204<sup>o</sup></td> <td>1407<sup>o</sup></td> <td>Tclk<sup>o</sup></td> </tr> <tr> <td rowspan="2">Clock<sup>o</sup></td> <td>Period<sup>o</sup></td> <td>T<sub>clk</sub><sup>o</sup></td> <td>25.0<sup>o</sup></td> <td>18.52<sup>o</sup></td> <td>14.81<sup>o</sup></td> <td>ns<sup>o</sup></td> </tr> <tr> <td>Frequency<sup>o</sup></td> <td>Freq<sup>o</sup></td> <td>40<sup>o</sup></td> <td>54<sup>o</sup></td> <td>67.5<sup>o</sup></td> <td>MHz<sup>o</sup></td> </tr> <tr> <td>Frame rate<sup>o</sup></td> <td>Frame rate<sup>o</sup></td> <td>F<sup>o</sup></td> <td>50<sup>o</sup></td> <td>60<sup>o</sup></td> <td>76<sup>o</sup></td> <td>Hz<sup>o</sup></td> </tr> </tbody> </table>	Signal <sup>o</sup>	Item <sup>o</sup>	Symbol <sup>o</sup>	Min <sup>o</sup>	Typ <sup>o</sup>	Max <sup>o</sup>	Unit <sup>o</sup>	Vertical Section <sup>o</sup>	Period <sup>o</sup>	T <sub>v</sub> <sup>o</sup>	1032 <sup>o</sup>	1066 <sup>o</sup>	1186 <sup>o</sup>	Th <sup>o</sup>	Active <sup>o</sup>	T <sub>disp(v)</sub> <sup>o</sup>	1024 <sup>o</sup>	1024 <sup>o</sup>	1024 <sup>o</sup>	Th <sup>o</sup>	Blanking <sup>o</sup>	T <sub>bp(v)+T<sub>ip(v)+PW<sub>vs</sub></sub><sup>o</sup></sub>	8 <sup>o</sup>	42 <sup>o</sup>	126 <sup>o</sup>	Th <sup>o</sup>	Horizontal Section <sup>o</sup>	Period <sup>o</sup>	T <sub>h</sub> <sup>o</sup>	780 <sup>o</sup>	844 <sup>o</sup>	2047 <sup>o</sup>	Tclk <sup>o</sup>	Active <sup>o</sup>	T <sub>disp(h)</sub> <sup>o</sup>	640 <sup>o</sup>	640 <sup>o</sup>	640 <sup>o</sup>	Tclk <sup>o</sup>	Blanking <sup>o</sup>	T <sub>bp(h)+T<sub>ip(h)+PW<sub>vs</sub></sub><sup>o</sup></sub>	140 <sup>o</sup>	204 <sup>o</sup>	1407 <sup>o</sup>	Tclk <sup>o</sup>	Clock <sup>o</sup>	Period <sup>o</sup>	T <sub>clk</sub> <sup>o</sup>	25.0 <sup>o</sup>	18.52 <sup>o</sup>	14.81 <sup>o</sup>	ns <sup>o</sup>	Frequency <sup>o</sup>	Freq <sup>o</sup>	40 <sup>o</sup>	54 <sup>o</sup>	67.5 <sup>o</sup>	MHz <sup>o</sup>	Frame rate <sup>o</sup>	Frame rate <sup>o</sup>	F <sup>o</sup>	50 <sup>o</sup>	60 <sup>o</sup>	76 <sup>o</sup>	Hz <sup>o</sup>	6.4 EE Timing: <table border="1"> <thead> <tr> <th>Signal<sup>o</sup></th> <th>Item<sup>o</sup></th> <th>Symbol<sup>o</sup></th> <th>Min<sup>o</sup></th> <th>Typ<sup>o</sup></th> <th>Max<sup>o</sup></th> <th>Unit<sup>o</sup></th> </tr> </thead> <tbody> <tr> <td rowspan="3">Vertical Section<sup>o</sup></td> <td>Period<sup>o</sup></td> <td>T<sub>v</sub><sup>o</sup></td> <td>1036<sup>o</sup></td> <td>1066<sup>o</sup></td> <td>1873<sup>o</sup></td> <td>Th<sup>o</sup></td> </tr> <tr> <td>Active<sup>o</sup></td> <td>T<sub>disp(v)</sub><sup>o</sup></td> <td>1024<sup>o</sup></td> <td>1024<sup>o</sup></td> <td>1024<sup>o</sup></td> <td>Th<sup>o</sup></td> </tr> <tr> <td>Blanking<sup>o</sup></td> <td>T<sub>bp(v)+T<sub>ip(v)+PW<sub>vs</sub></sub><sup>o</sup></sub></td> <td>12<sup>o</sup></td> <td>42<sup>o</sup></td> <td>849<sup>o</sup></td> <td>Th<sup>o</sup></td> </tr> <tr> <td rowspan="3">Horizontal Section<sup>o</sup></td> <td>Period<sup>o</sup></td> <td>T<sub>h</sub><sup>o</sup></td> <td>730<sup>o</sup></td> <td>844<sup>o</sup></td> <td>1320<sup>o</sup></td> <td>Tclk<sup>o</sup></td> </tr> <tr> <td>Active<sup>o</sup></td> <td>T<sub>disp(h)</sub><sup>o</sup></td> <td>640<sup>o</sup></td> <td>640<sup>o</sup></td> <td>640<sup>o</sup></td> <td>Tclk<sup>o</sup></td> </tr> <tr> <td>Blanking<sup>o</sup></td> <td>T<sub>bp(h)+T<sub>ip(h)+PW<sub>vs</sub></sub><sup>o</sup></sub></td> <td>90<sup>o</sup></td> <td>204<sup>o</sup></td> <td>680<sup>o</sup></td> <td>Tclk<sup>o</sup></td> </tr> <tr> <td rowspan="2">Clock<sup>o</sup></td> <td>Period<sup>o</sup></td> <td>T<sub>clk</sub><sup>o</sup></td> <td>14.6<sup>o</sup></td> <td>18.5<sup>o</sup></td> <td>26.4<sup>o</sup></td> <td>ns<sup>o</sup></td> </tr> <tr> <td>Frequency<sup>o</sup></td> <td>Freq<sup>o</sup></td> <td>37.8<sup>o</sup></td> <td>54<sup>o</sup></td> <td>68.4<sup>o</sup></td> <td>MHz<sup>o</sup></td> </tr> <tr> <td>Frame rate<sup>o</sup></td> <td>Frame rate<sup>o</sup></td> <td>F<sup>o</sup></td> <td>50<sup>o</sup></td> <td>60<sup>o</sup></td> <td>76<sup>o</sup></td> <td>Hz<sup>o</sup></td> </tr> <tr> <td></td> <td></td> <td>H<sub>sync</sub> Frequency<sup>o</sup></td> <td>51.8<sup>o</sup></td> <td>64<sup>o</sup></td> <td>93.7<sup>o</sup></td> <td>KHz<sup>o</sup></td> </tr> </tbody> </table>	Signal <sup>o</sup>	Item <sup>o</sup>	Symbol <sup>o</sup>	Min <sup>o</sup>	Typ <sup>o</sup>	Max <sup>o</sup>	Unit <sup>o</sup>	Vertical Section <sup>o</sup>	Period <sup>o</sup>	T <sub>v</sub> <sup>o</sup>	1036 <sup>o</sup>	1066 <sup>o</sup>	1873 <sup>o</sup>	Th <sup>o</sup>	Active <sup>o</sup>	T <sub>disp(v)</sub> <sup>o</sup>	1024 <sup>o</sup>	1024 <sup>o</sup>	1024 <sup>o</sup>	Th <sup>o</sup>	Blanking <sup>o</sup>	T <sub>bp(v)+T<sub>ip(v)+PW<sub>vs</sub></sub><sup>o</sup></sub>	12 <sup>o</sup>	42 <sup>o</sup>	849 <sup>o</sup>	Th <sup>o</sup>	Horizontal Section <sup>o</sup>	Period <sup>o</sup>	T <sub>h</sub> <sup>o</sup>	730 <sup>o</sup>	844 <sup>o</sup>	1320 <sup>o</sup>	Tclk <sup>o</sup>	Active <sup>o</sup>	T <sub>disp(h)</sub> <sup>o</sup>	640 <sup>o</sup>	640 <sup>o</sup>	640 <sup>o</sup>	Tclk <sup>o</sup>	Blanking <sup>o</sup>	T <sub>bp(h)+T<sub>ip(h)+PW<sub>vs</sub></sub><sup>o</sup></sub>	90 <sup>o</sup>	204 <sup>o</sup>	680 <sup>o</sup>	Tclk <sup>o</sup>	Clock <sup>o</sup>	Period <sup>o</sup>	T <sub>clk</sub> <sup>o</sup>	14.6 <sup>o</sup>	18.5 <sup>o</sup>	26.4 <sup>o</sup>	ns <sup>o</sup>	Frequency <sup>o</sup>	Freq <sup>o</sup>	37.8 <sup>o</sup>	54 <sup>o</sup>	68.4 <sup>o</sup>	MHz <sup>o</sup>	Frame rate <sup>o</sup>	Frame rate <sup>o</sup>	F <sup>o</sup>	50 <sup>o</sup>	60 <sup>o</sup>	76 <sup>o</sup>	Hz <sup>o</sup>			H <sub>sync</sub> Frequency <sup>o</sup>	51.8 <sup>o</sup>	64 <sup>o</sup>	93.7 <sup>o</sup>	KHz <sup>o</sup>	
Signal <sup>o</sup>	Item <sup>o</sup>	Symbol <sup>o</sup>	Min <sup>o</sup>	Typ <sup>o</sup>	Max <sup>o</sup>	Unit <sup>o</sup>																																																																																																																																							
Vertical Section <sup>o</sup>	Period <sup>o</sup>	T <sub>v</sub> <sup>o</sup>	1032 <sup>o</sup>	1066 <sup>o</sup>	1186 <sup>o</sup>	Th <sup>o</sup>																																																																																																																																							
	Active <sup>o</sup>	T <sub>disp(v)</sub> <sup>o</sup>	1024 <sup>o</sup>	1024 <sup>o</sup>	1024 <sup>o</sup>	Th <sup>o</sup>																																																																																																																																							
	Blanking <sup>o</sup>	T <sub>bp(v)+T<sub>ip(v)+PW<sub>vs</sub></sub><sup>o</sup></sub>	8 <sup>o</sup>	42 <sup>o</sup>	126 <sup>o</sup>	Th <sup>o</sup>																																																																																																																																							
Horizontal Section <sup>o</sup>	Period <sup>o</sup>	T <sub>h</sub> <sup>o</sup>	780 <sup>o</sup>	844 <sup>o</sup>	2047 <sup>o</sup>	Tclk <sup>o</sup>																																																																																																																																							
	Active <sup>o</sup>	T <sub>disp(h)</sub> <sup>o</sup>	640 <sup>o</sup>	640 <sup>o</sup>	640 <sup>o</sup>	Tclk <sup>o</sup>																																																																																																																																							
	Blanking <sup>o</sup>	T <sub>bp(h)+T<sub>ip(h)+PW<sub>vs</sub></sub><sup>o</sup></sub>	140 <sup>o</sup>	204 <sup>o</sup>	1407 <sup>o</sup>	Tclk <sup>o</sup>																																																																																																																																							
Clock <sup>o</sup>	Period <sup>o</sup>	T <sub>clk</sub> <sup>o</sup>	25.0 <sup>o</sup>	18.52 <sup>o</sup>	14.81 <sup>o</sup>	ns <sup>o</sup>																																																																																																																																							
	Frequency <sup>o</sup>	Freq <sup>o</sup>	40 <sup>o</sup>	54 <sup>o</sup>	67.5 <sup>o</sup>	MHz <sup>o</sup>																																																																																																																																							
Frame rate <sup>o</sup>	Frame rate <sup>o</sup>	F <sup>o</sup>	50 <sup>o</sup>	60 <sup>o</sup>	76 <sup>o</sup>	Hz <sup>o</sup>																																																																																																																																							
Signal <sup>o</sup>	Item <sup>o</sup>	Symbol <sup>o</sup>	Min <sup>o</sup>	Typ <sup>o</sup>	Max <sup>o</sup>	Unit <sup>o</sup>																																																																																																																																							
Vertical Section <sup>o</sup>	Period <sup>o</sup>	T <sub>v</sub> <sup>o</sup>	1036 <sup>o</sup>	1066 <sup>o</sup>	1873 <sup>o</sup>	Th <sup>o</sup>																																																																																																																																							
	Active <sup>o</sup>	T <sub>disp(v)</sub> <sup>o</sup>	1024 <sup>o</sup>	1024 <sup>o</sup>	1024 <sup>o</sup>	Th <sup>o</sup>																																																																																																																																							
	Blanking <sup>o</sup>	T <sub>bp(v)+T<sub>ip(v)+PW<sub>vs</sub></sub><sup>o</sup></sub>	12 <sup>o</sup>	42 <sup>o</sup>	849 <sup>o</sup>	Th <sup>o</sup>																																																																																																																																							
Horizontal Section <sup>o</sup>	Period <sup>o</sup>	T <sub>h</sub> <sup>o</sup>	730 <sup>o</sup>	844 <sup>o</sup>	1320 <sup>o</sup>	Tclk <sup>o</sup>																																																																																																																																							
	Active <sup>o</sup>	T <sub>disp(h)</sub> <sup>o</sup>	640 <sup>o</sup>	640 <sup>o</sup>	640 <sup>o</sup>	Tclk <sup>o</sup>																																																																																																																																							
	Blanking <sup>o</sup>	T <sub>bp(h)+T<sub>ip(h)+PW<sub>vs</sub></sub><sup>o</sup></sub>	90 <sup>o</sup>	204 <sup>o</sup>	680 <sup>o</sup>	Tclk <sup>o</sup>																																																																																																																																							
Clock <sup>o</sup>	Period <sup>o</sup>	T <sub>clk</sub> <sup>o</sup>	14.6 <sup>o</sup>	18.5 <sup>o</sup>	26.4 <sup>o</sup>	ns <sup>o</sup>																																																																																																																																							
	Frequency <sup>o</sup>	Freq <sup>o</sup>	37.8 <sup>o</sup>	54 <sup>o</sup>	68.4 <sup>o</sup>	MHz <sup>o</sup>																																																																																																																																							
Frame rate <sup>o</sup>	Frame rate <sup>o</sup>	F <sup>o</sup>	50 <sup>o</sup>	60 <sup>o</sup>	76 <sup>o</sup>	Hz <sup>o</sup>																																																																																																																																							
		H <sub>sync</sub> Frequency <sup>o</sup>	51.8 <sup>o</sup>	64 <sup>o</sup>	93.7 <sup>o</sup>	KHz <sup>o</sup>																																																																																																																																							
	12	3. Function Block Diagram : 	3. Function Block Diagram : 																																																																																																																																										
	18	5.2 Backlight Unit :	5.2 Backlight Unit :																																																																																																																																										

		Description / LED Operation Current Symbol / VLB	Description / LED <b>Forward</b> Current Symbol / <b>VLED</b>															
	25	7.1 TFT LCD Module : Manufacturer : JAE / P-TWO Type Part Number : 187034-30091 / FI-XB30SSLA-HF15	7.1 TFT LCD Module : Manufacturer : P-TWO / <b>STM</b> Type Part Number : 187034-30091 / <b>MSBKT2407P30HB</b>															
	26	7.2 LED Connector on Backlight Unit This connector is mounted on LED light bar. <table border="1" data-bbox="379 555 821 622"> <thead> <tr> <th>Connector Name / Designation</th> <th>Light Bar Connector</th> </tr> </thead> <tbody> <tr> <td>Manufacturer</td> <td>ENTERY INDUSTRIAL CO., LTD.</td> </tr> <tr> <td>Type Part Number</td> <td>3707K-S06N-21R</td> </tr> </tbody> </table>	Connector Name / Designation	Light Bar Connector	Manufacturer	ENTERY INDUSTRIAL CO., LTD.	Type Part Number	3707K-S06N-21R	7.2 LED Connector on Backlight Unit This connector is mounted on LED light bar. <table border="1" data-bbox="853 555 1295 654"> <thead> <tr> <th>Connector Name / Designation</th> <th>Light Bar Connector</th> </tr> </thead> <tbody> <tr> <td>Manufacturer</td> <td>ENTERY INDUSTRIAL CO., LTD.</td> </tr> <tr> <td>Type Part Number</td> <td>3707K-S06N-21R</td> </tr> <tr> <td>Mating Housing Part Number</td> <td>H112K-P06N-13B (Locked Type)</td> </tr> </tbody> </table>	Connector Name / Designation	Light Bar Connector	Manufacturer	ENTERY INDUSTRIAL CO., LTD.	Type Part Number	3707K-S06N-21R	Mating Housing Part Number	H112K-P06N-13B (Locked Type)	
Connector Name / Designation	Light Bar Connector																	
Manufacturer	ENTERY INDUSTRIAL CO., LTD.																	
Type Part Number	3707K-S06N-21R																	
Connector Name / Designation	Light Bar Connector																	
Manufacturer	ENTERY INDUSTRIAL CO., LTD.																	
Type Part Number	3707K-S06N-21R																	
Mating Housing Part Number	H112K-P06N-13B (Locked Type)																	
1.1 2012/10/23	6	2.1 Display Characteristics / Power Consumption / 11.03 watt	2.1 Display Characteristics / Power Consumption / 11.15 watt															

## 1 Handling Precautions

- 1) Since front polarizer is easily damaged, pay attention not to scratch it.
- 2) Be sure to turn off power supply when inserting or disconnecting from input connector.
- 3) Wipe off water drop immediately. Long contact with water may cause discoloration or spots.
- 4) When the panel surface is soiled, wipe it with absorbent cotton or other soft cloth.
- 5) Since the panel is made of glass, it may break or crack if dropped or bumped on hard surface.
- 6) Since CMOS LSI is used in this module, take care of static electricity and insure human earth when handling.
- 7) Do not open or modify the Module Assembly.
- 8) Do not press the reflector sheet at the back of the module to any directions.
- 9) In case if a Module has to be put back into the packing container slot after once it was taken out from the container, do not press the center of LED light bar edge. Instead, press at the far ends of the LED light bar edge softly. Otherwise the TFT Module may be damaged.
- 10) At the insertion or removal of the Signal Interface Connector, be sure not to rotate nor tilt the Interface Connector of the TFT Module.
- 11) After installation of the TFT Module into an enclosure, do not twist nor bend the TFT Module even momentary. At designing the enclosure, it should be taken into consideration that no bending/twisting forces are applied to the TFT Module from outside. Otherwise the TFT Module may be damaged.
- 12) Small amount of materials having no flammability grade is used in the LCD module. The LCD module should be supplied by power complied with requirements of Limited Power Source (IEC60950 or UL1950), or be applied exemption.
- 13) Avoid touching COF position while doing mechanical design.
- 14) While storing modules as spares for a long time, the following precautions are necessary:
  - Store modules in a dark place. Do not expose them to sunlight or fluorescent light.
  - Keep the temperature between 5°C and 35°C at normal humidity.
- 15) Pls avoid touching COF position while you are doing mechanical design.
- 16) When storing modules as spares for a long time, the following precaution is necessary: Store them in a dark place. Do not expose the module to sunlight or fluorescent light. Keep the temperature between 5°C and 35°C at normal humidity.

## 2 General Description

This specification applies to the 19 inch-SXGA color a-Si TFT-LCD Module M190ETN01.0. The display supports the SXGA - 1280(H) x 1024(V) screen format and 16.7M colors (RGB 6-bit data + HiFRC data). The light source of this TFT-LCD module is W-LED. All input signals are 2-channel LVDS interface and this module doesn't contain a driver for backlight.

### 2.1 Display Characteristics

The following items are characteristics summary on the table under 25°C condition:

Items	Unit	Specification
Screen Diagonal	[mm]	482.6 (19.0" )
Active Area	[mm]	376.32 (H) x 301.06 (V)
Pixels H x V		1280(x3) x 1024
Pixel Pitch	[um]	0.294 (per one triad) x 0.294
Pixel Arrangement		R.G.B. Vertical Stripe
Display Mode		Normally White
White Luminance ( Center )	[cd/m2]	250 (center, Typ) @60.0mA
Contrast Ratio		1000 : 1 (Typ)
Optical Response Time	[msec]	5 ms(Typ, on/off)
Nominal Input Voltage VDD	[Volt]	+5.0 V
Power Consumption (VDD line + LED line)	[Watt]	11.15 watt VDD line : PDD (typ), All black pattern at 60Hz =2.7W LED line : PBLU (typ) = 8.45W
Weight	[g]	1800 (Typ)
Physical Size	[mm]	396 (H) x 324 (V) x 10.9(D) (Typ)
Electrical Interface		Dual channel LVDS
Support Color		16.7M colors (RGB 6-bit + Hi_FRC)
Surface Treatment		Anti-Glare, 3H
Temperature Range		
Operating	[°C]	0 to +50
Storage (Shipping)	[°C]	-20 to +60
RoHS Compliance		RoHS Compliance
TCO Compliance		TCO 6.0 Compliance

## 2.2 Optical Characteristics

The optical characteristics are measured under stable conditions at 25°C:

Item	Unit	Conditions	Min.	Typ.	Max.	Note
Viewing Angle	[degree]	Horizontal (Right)	75	85	-	<b>2</b>
		CR = 10 (Left)	75	85		
		Vertical (Up)	70	80	-	
CR = 10 (Down)	70	80				
Contrast Ratio		Normal Direction	600	1000	-	<b>3</b>
Response Time	[msec]	Rising Time (TrR)	-	3.6	5.7	<b>4</b>
		Falling Time (TrF)	-	1.4	2.3	
		Rising + Falling	-	5	8	
		Gray to Gray(16x16 avg.)				
Color / Chromaticity Coordinates (CIE)		Red x	0.609	0.639	0.669	<b>5</b>
		Red y	0.316	0.346	0.376	
		Green x	0.294	0.324	0.354	
		Green y	0.597	0.627	0.657	
		Blue x	0.124	0.154	0.184	
		Blue y	0.024	0.054	0.084	
Color Coordinates (CIE) White		White x	0.283	0.313	0.343	
		White y	0.299	0.329	0.359	
Central Luminance	[cd/m <sup>2</sup> ]		200	250	-	<b>6</b>
Luminance Uniformity	[%]		75	80	-	<b>7</b>
Crosstalk (in 60Hz)	[%]				1.5	<b>8</b>
Flicker	dB				-20	<b>9</b>



## Note 1: Measurement Method

The LCD module should be stabilized at given temperature for 30 minutes to avoid abrupt temperature change during measuring (at surface 35°C). In order to stabilize the luminance, the measurement should be executed after lighting Backlight for 30 minutes in a stable, windless and dark room.

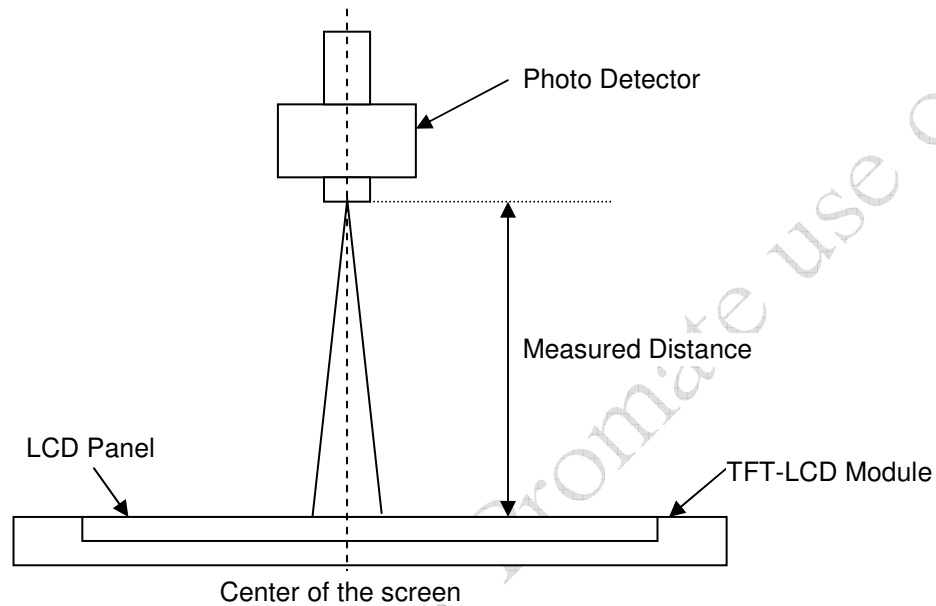

## Note 2: Definition of Viewing Angle measured by ELDIM (EZContrast 88)

Viewing angle is the measurement of contrast ratio  $\geq 10$ , at the screen center, over a 180° horizontal and 180° vertical range (off-normal viewing angles). The 180° viewing angle range is broken down as follows; 90° ( $\theta$ ) horizontal left and right and 90° ( $\phi$ ) vertical, high (up) and low (down). The measurement direction is typically perpendicular to the display surface with the screen rotated about its center to develop the desired measurement viewing angle.

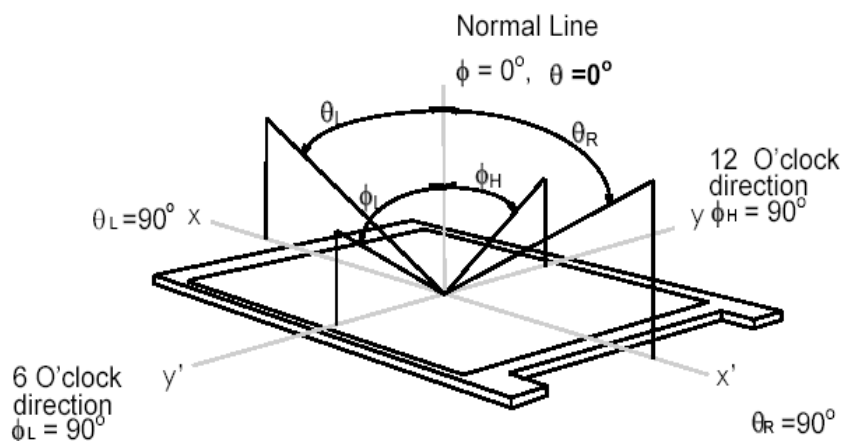



**Note 3: Contrast Ratio** measured by TOPCON SR-3

**Note 4: Definition of Response time** measured by Westar TRD-100A

The output signals of photo detector are measured when the input signals are changed from “Full Black” to “Full White” (rising time,  $T_{rR}$ ), and from “Full White” to “Full Black” (falling time,  $T_{rF}$ ), respectively. The response time is interval between the 10% and 90% (1 frame at 60 Hz) of amplitudes.

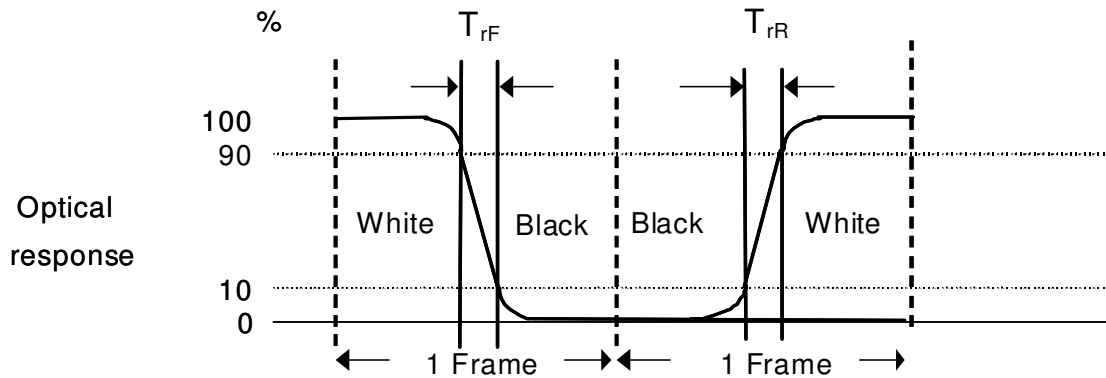

$T_{rR} + T_{rF} = 5 \text{ msec (typ.)}$ .

Algorithm:  $|\text{Gray Level A} - \text{Gray Level B}| \geq 16$ , then the average gray to gray response time is 2 ms, (F= 60 Hz)

**Note 5: Color Chromaticity and Coordinates (CIE)** measured by TOPCON SR-3

**Note 6: Central Luminance** measured by TOPCON SR-3

**Note 7: Luminance Uniformity** of these 9 points defined as below and measured by TOPCON SR-3

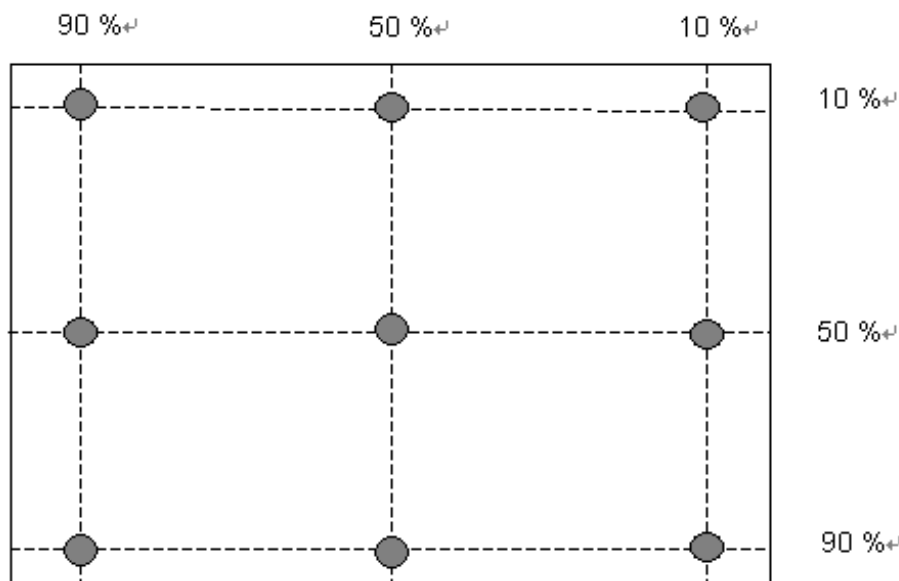

$$\text{Uniformity} = \frac{\text{Minimum Luminance in 9 points (1-9)}}{\text{Maximum Luminance in 9 Points (1-9)}}$$

**Note 8: Crosstalk** defined as below and measured by TOPCON SR-3

$$CT = | YB - YA | / YA \times 100 (\%)$$

Where

YA = Luminance of measured location without gray level 0 pattern (cd/m<sup>2</sup>)

YB = Luminance of measured location with gray level 0 pattern (cd/m<sup>2</sup>)

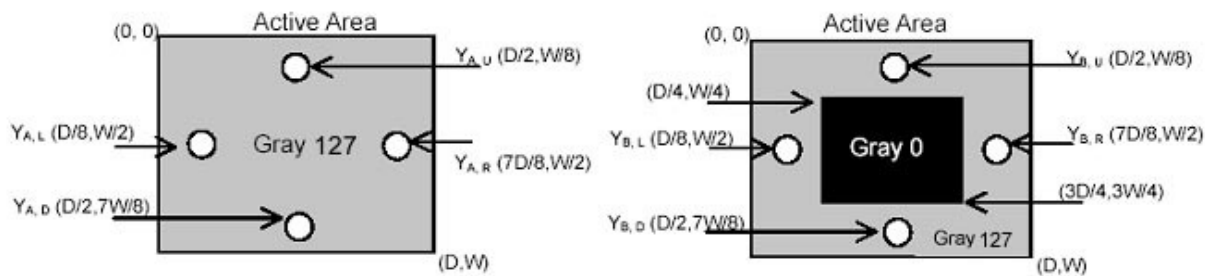

**Note 9: Test Pattern Sub-checker Pattern** measured by TOPCON SR-3

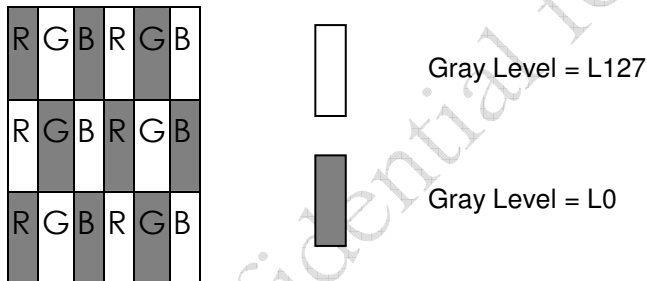

Method: Record dBV & DC value with TRD-100

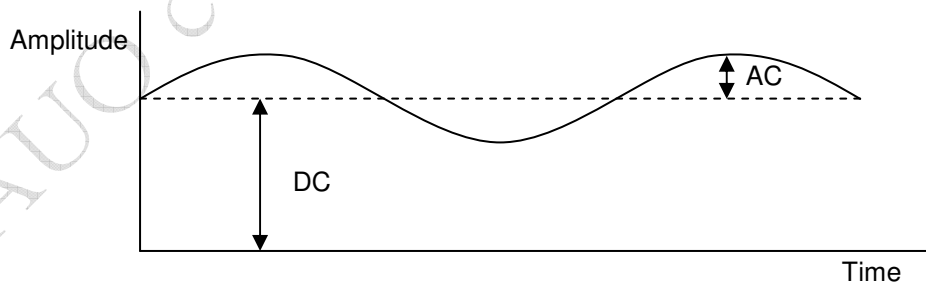

$$\text{Flicker (dB)} = 20 \log \frac{\text{AC Level (at 30 Hz)}}{\text{DC Level}}$$

## 2.3 Mechanical Characteristics

Item	Unit	Min.	Note
Compression Endurance	[Kgf]	2.5	1

Note 1: Test Method

The point is at a distance from right-downside 25mm x 25mm defined as the Start Point of Measure Points, and the point is at a distance 25mm from left-side & around 10mm from PCB defined as the End Point.

Align 50mm x 50mm block from Start Point on the Bezel Back, and the corners of each block are Measure Points.

If the distance from the last block to each side of the End Point  $\geq 25$ mm, add other blocks to make sure that most area of Bezel Back can be measured.

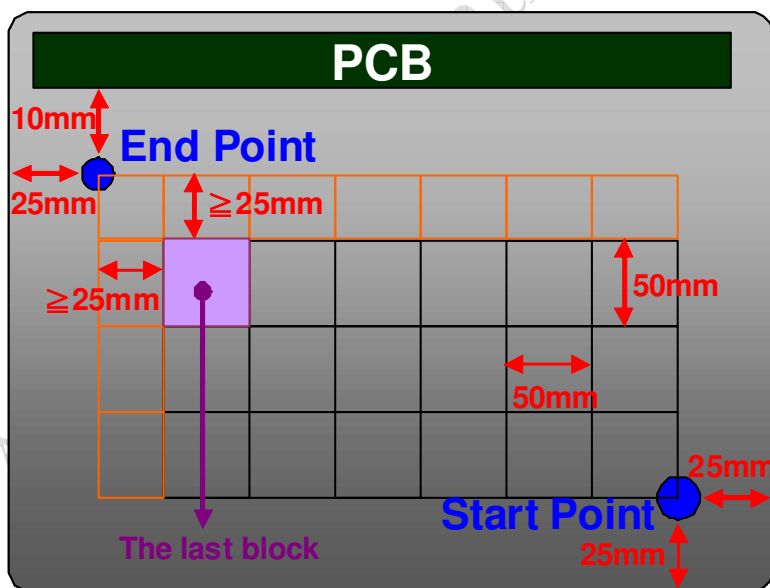

## 3 Functional Block Diagram

The following diagram shows the functional block of the 19.0 inch Color TFT-LCD Module:

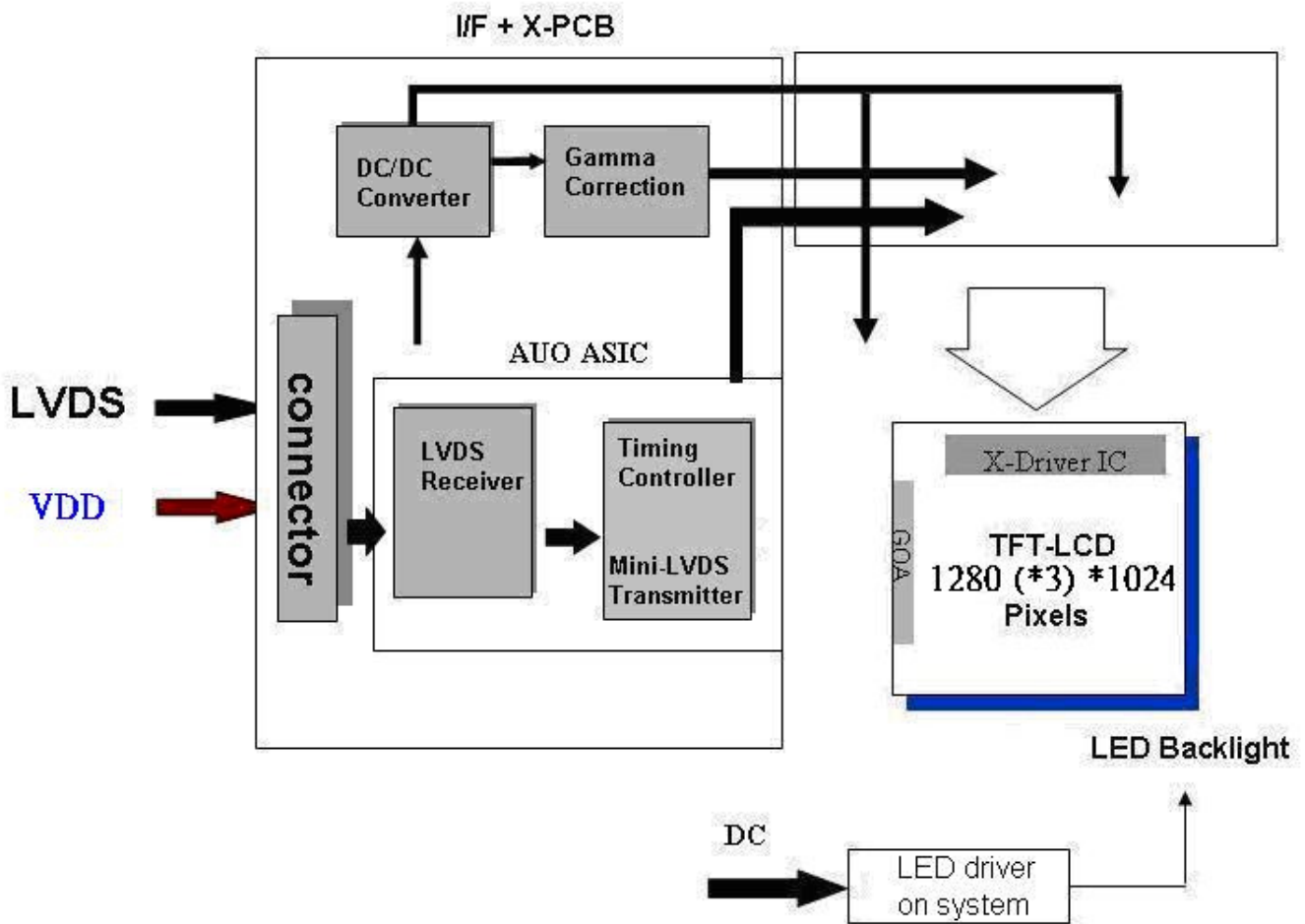

AUO confide

## 4 Absolute Maximum Ratings

Absolute maximum ratings of the module are listed as follows:

### 4.1 TFT LCD Module

Item	Symbol	Min	Max	Unit	Conditions
Logic/LCD Drive	VDD	-0.3	6.0	[Volt]	Note 1, 2

### 4.2 Backlight Unit

Item	Symbol	Min	Max	Unit	Conditions
LED Forward Current	IRLED1	0	90	[mA]	Note 1,2,5 100% duty
	IRLED2				
	IRLED3				
	IRLED4				
LED Pulse Forward Current	IPLED1	-	150	[mA]	Note 1,2,5 10% duty @100Hz
	IPLED2				
	IPLED3				
	IPLED4				
LED forward Voltage variation (per string variation)	$\Delta V_f$	-	2.2	[Volt]	Note 1,2

### 4.3 Absolute Ratings of Environment

Item	Symbol	Min.	Max.	Unit	Conditions
Operating Temperature	TOP	0	+50	[°C]	Note 3
Glass Surface Temperature	TGS	0	+65	[°C]	Note3 Note4
Operation Humidity	HOP	5	90	[%RH]	Note 3
Storage Temperature	TST	-20	+60	[°C]	
Storage Humidity	HST	5	90	[%RH]	

**Note 1:** With in Ta (25°C)

**Note 2:** Permanent damage to the device may occur if exceeding maximum values

**Note 3:** Temperature and relative humidity range are shown as the below figure.

1. 90% RH Max ( Ta  $\leq$ 39°C)
2. Max wet-bulb temperature at 39°C or less. ( Ta  $\leq$ 39°C)
3. No condensation

**Note 4:** Function Judged only

**Note 5:** IRLED1,2,3,4 and IPLED1,2,3,4 define as per strings LED current.

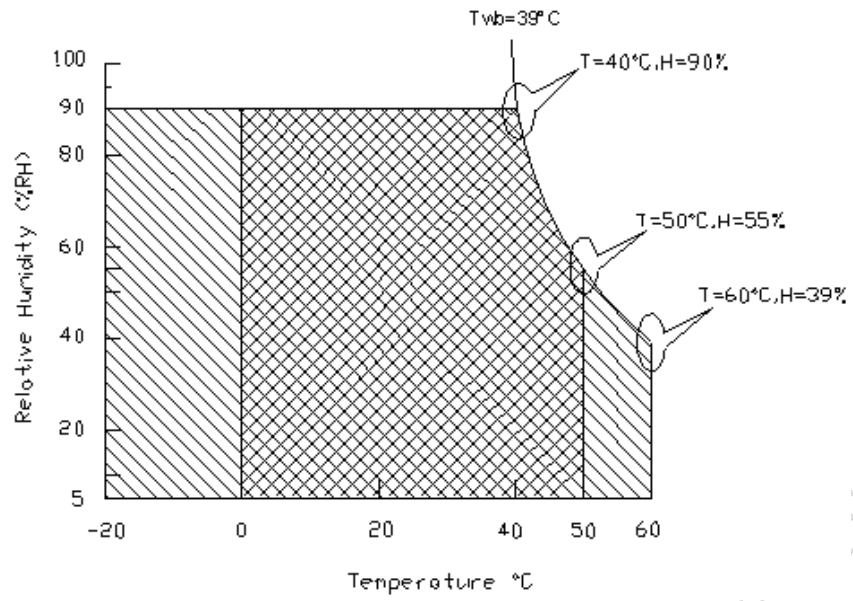

Operating Range  Storage Range  + 

## 5 Electrical Characteristics

### 5.1 TFT LCD Module

#### 5.1.1 Power Specification

Input power specifications are listed as follows:

Symbol	Description	Min	Typ.	Max	Unit	Conditions
VDD	Logic/LCD Drive Voltage	4.5	5.0	5.5	[Volt]	+/-10%
IDD1	Input Current	-	0.53	0.64	[A]	VDD= 5.0V, All black Pattern at 60 Hz
		-	0.61	0.73	[A]	VDD= 5.0V, All black Pattern at 75 Hz
PDD1	VDD Power	-	2.7	3.2	[Watt]	VDD= 5.0V, All black Pattern at 60 Hz
		-	3.05	3.7	[Watt]	VDD= 5.0V, All black Pattern at 75 Hz
IRush	Inrush Current	-	-	3	[A]	<b>Note 1</b>
VDDrp	Allowable Logic/LCD Drive Ripple Voltage	-	-	500	[mV] p-p	VDD= 5.0V, All black Pattern at 75 Hz

#### Note 1: Measurement Conditions:

The duration of rising time of power input is 470 us.

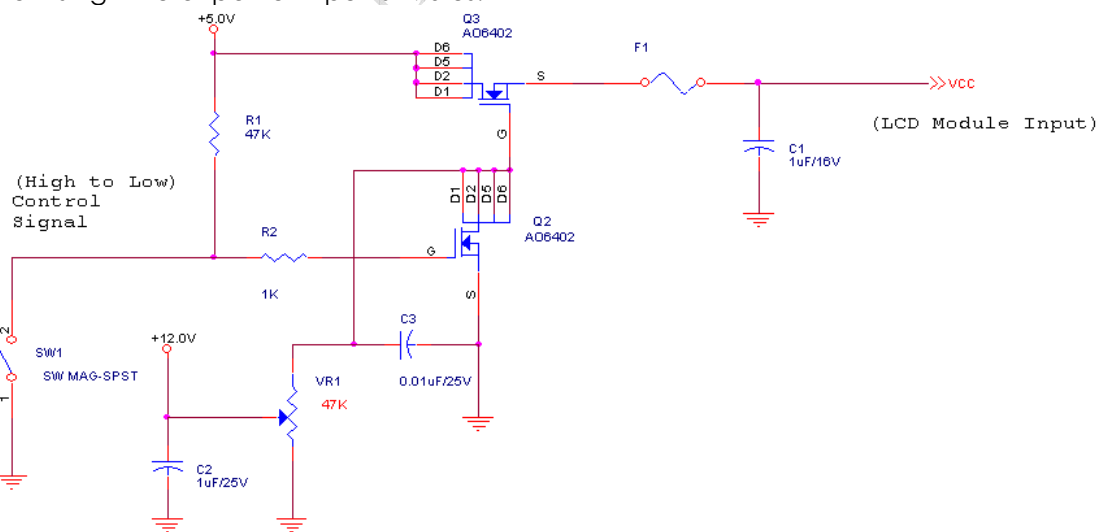



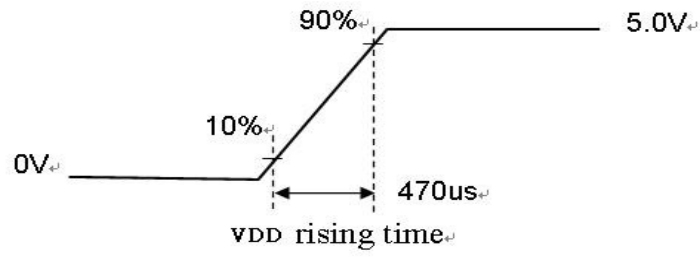

AUO confidential for Promate use only

## 5.1.2 Signal Electrical Characteristics

(1) DC Characteristics of each signal are as following:

Symbol	Description	Min	Typ	Max	Units	Conditions
$V_{TH}$	Differential Input High Threshold	-	-	+100	[mV]	$V_{CM} = 1.2V$ <b>Note 1</b>
$V_{TL}$	Differential Input Low Threshold	-100	-	-	[mV]	$V_{CM} = 1.2V$ <b>Note 1</b>
$ V_{ID} $	Input Differential Voltage	100	-	600	[mV]	<b>Note 1</b>
$V_{CM}$	Differential Input Common Mode Voltage	+1.0	+1.2	+1.5	[V]	$V_{TH}-V_{TL} = 200mV$ (max) <b>Note 1</b>

**Note 1:** LVDS Signal Waveform

### Single-End

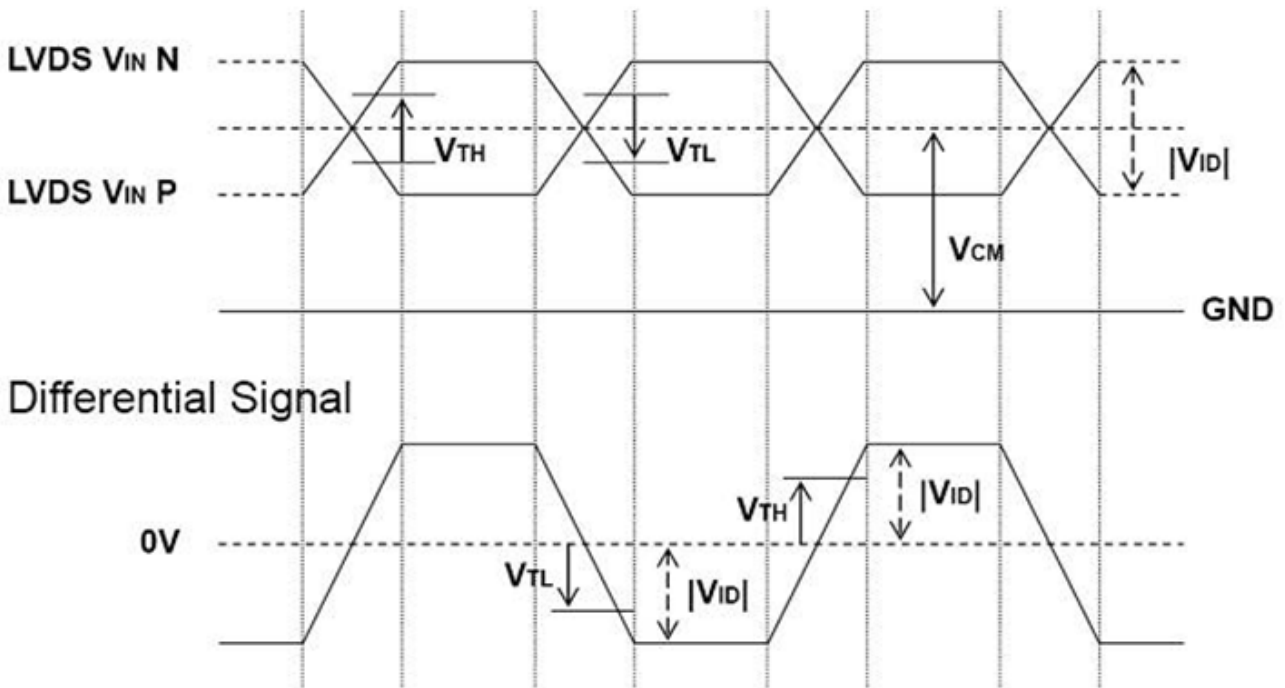

## (2) AC Characteristics

Symbol	Description	Min	Max	Units	Conditions
$F_{DEV}$	Maximum deviation of input clock frequency during SSC	-	$\pm 3$	%	
$F_{MOD}$	Maximum modulation frequency of input clock during SSC	-	200	KHz	

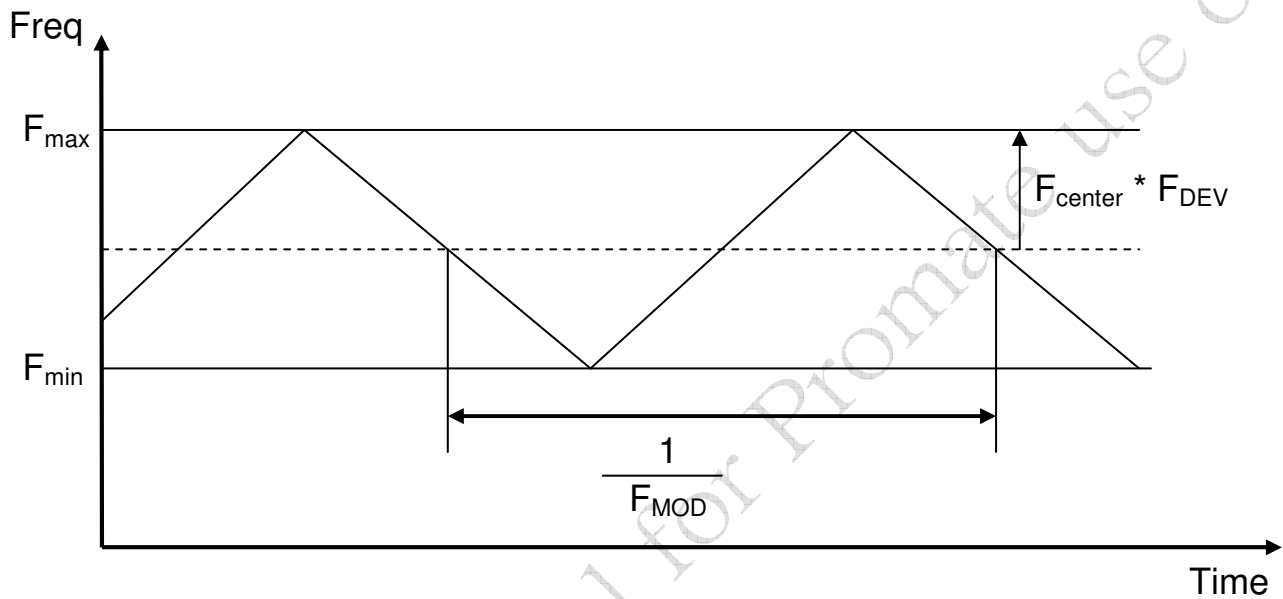

< Spread Spectrum >

## 5.2 Backlight Unit

Parameter guideline for LED driving is under stable conditions at 25 °C (Room Temperature):

Symbol	Description	Min.	Typ.	Max.	Unit	Note
IRLED1	LED Forward Current	-	60	63	[mA]	<b>Note 1</b>
IRLED2						
IRLED3						
IRLED4						
VLED	Light Bar Operation Voltage (for reference)	33.0	35.2	37.4	[Volt]	<b>Note 2</b>
PBLU	BLU Power Consumption (for reference)	-	8.45	9.42	[Watt]	<b>Note 3</b>
LTLED	LED Life Time (Typical)	30,000	-	-	[Hour]	<b>Note 4</b>

Each module consists of 44 pcs LED ( 4 strings x 11 pcs / string )

**Note 1:** The specified current is 100% duty of LED chip input current, IRLED1,2,3,4 define as per strings LED current.

**Note 2:** The value showed is one string operation voltage.

**Note 3:**  $PBLU = VLED * (IRLED1 + IRLED2 + IRLED3 + IRLED4)$

**Note 4:** Definition of life time: Brightness becomes to 50% of its original value. The minimum life time of LED unit is on the condition of IRLED = 60mA and 25±2°C (Room Temperature).



## 6.3 Signal Description

PIN #	SIGNAL NAME	DESCRIPTION
1	RxOIN0-	Negative LVDS differential data input (Odd data)
2	RxOIN0+	Positive LVDS differential data input (Odd data)
3	RxOIN1-	Negative LVDS differential data input (Odd data)
4	RxOIN1+	Positive LVDS differential data input (Odd data)
5	RxOIN2-	Negative LVDS differential data input (Odd data, DSPTMG)
6	RxOIN2+	Positive LVDS differential data input (Odd data, DSPTMG)
7	GND	Power Ground
8	RxOCLK-	Negative LVDS differential clock input (Odd clock)
9	RxOCLK+	Positive LVDS differential clock input (Odd clock)
10	RxOIN3-	Negative LVDS differential data input (Odd data)
11	RxOIN3+	Positive LVDS differential data input (Odd data)
12	RxEIN0-	Negative LVDS differential data input (Even data)
13	RxEIN0+	LVDS differential data input (Even data)
14	GND	Power Ground
15	RxEIN1-	Negative LVDS differential data input (Even data)
16	RxEIN1+	Positive LVDS differential data input (Even data)
17	GND	Power Ground
18	RxEIN2-	Negative LVDS differential data input (Even data)
19	RxEIN2+	Positive LVDS differential data input (Even data)
20	RxECLK-	Negative LVDS differential clock input (Even clock)
21	RxECLK+	Positive LVDS differential clock input (Even clock)
22	RxEIN3-	Negative LVDS differential data input (Even data)
23	RxEIN3+	Positive LVDS differential data input (Even data)
24	GND	Power Ground
25	NC	No connection (for AUO test only. Do not connect)
26	NC	No connection (for AUO test only. Do not connect)
27	NC	No connection (for AUO test only. Do not connect)
28	VDD	Power +5V
29	VDD	Power +5V
30	VDD	Power +5V

**Note 1:** Input signals of odd and even clock shall be the same timing.

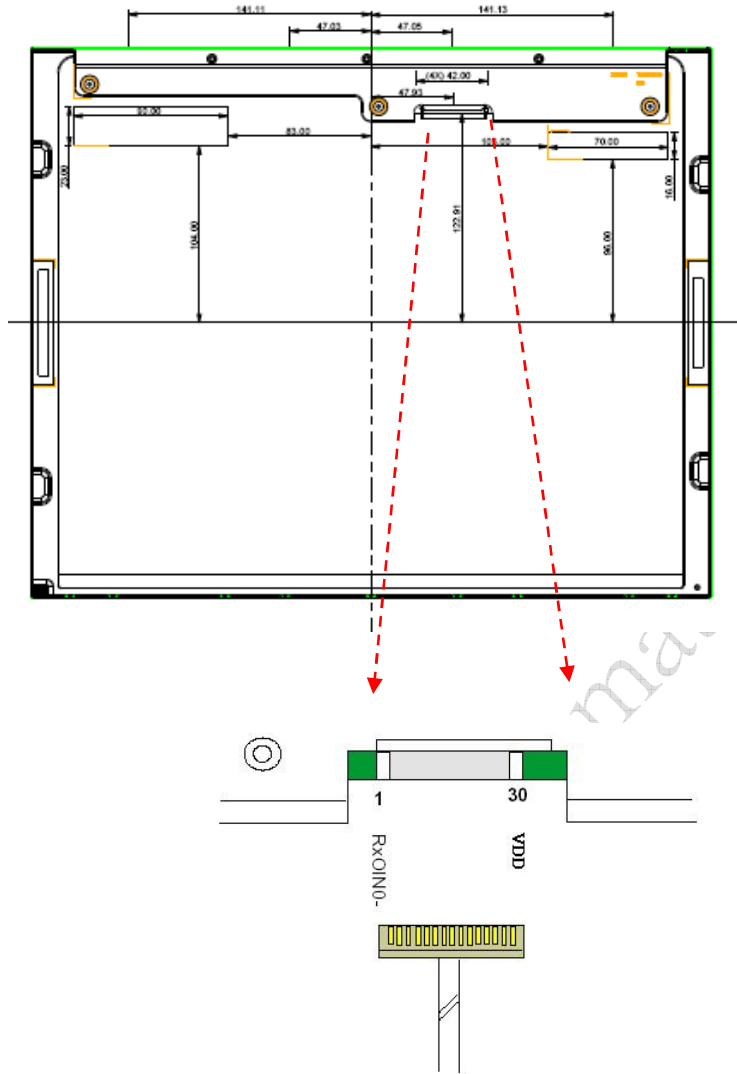

AUO confidential



## 6.4 Timing Characteristics

The input signal timing specifications are shown as the following table

Signal	Item	Symbol	Min	Typ	Max	Unit
Vertical Section	Period	Tv	1036	1066	1873	Th
	Active	Tdisp(v)	1024	1024	1024	Th
	Blanking	Tbp(v)+Tfp(v)+PWvs	12	42	849	Th
Horizontal Section	Period	Th	730	844	1320	Tclk
	Active	Tdisp(h)	640	640	640	Tclk
	Blanking	Tbp(h)+Tfp(h)+PWhs	90	204	680	Tclk
Clock	Period	Tclk	14.6	18.5	26.4	ns
	Frequency	Freq	37.8	54	68.4	MHz
Frame rate	Frame rate	F	50	60	76	Hz
Hsync Frequency	Hsync Frequency	HFreq	51.8	64	93.7	KHz

**Note 1:** DE mode only

## 6.5 Timing Diagram

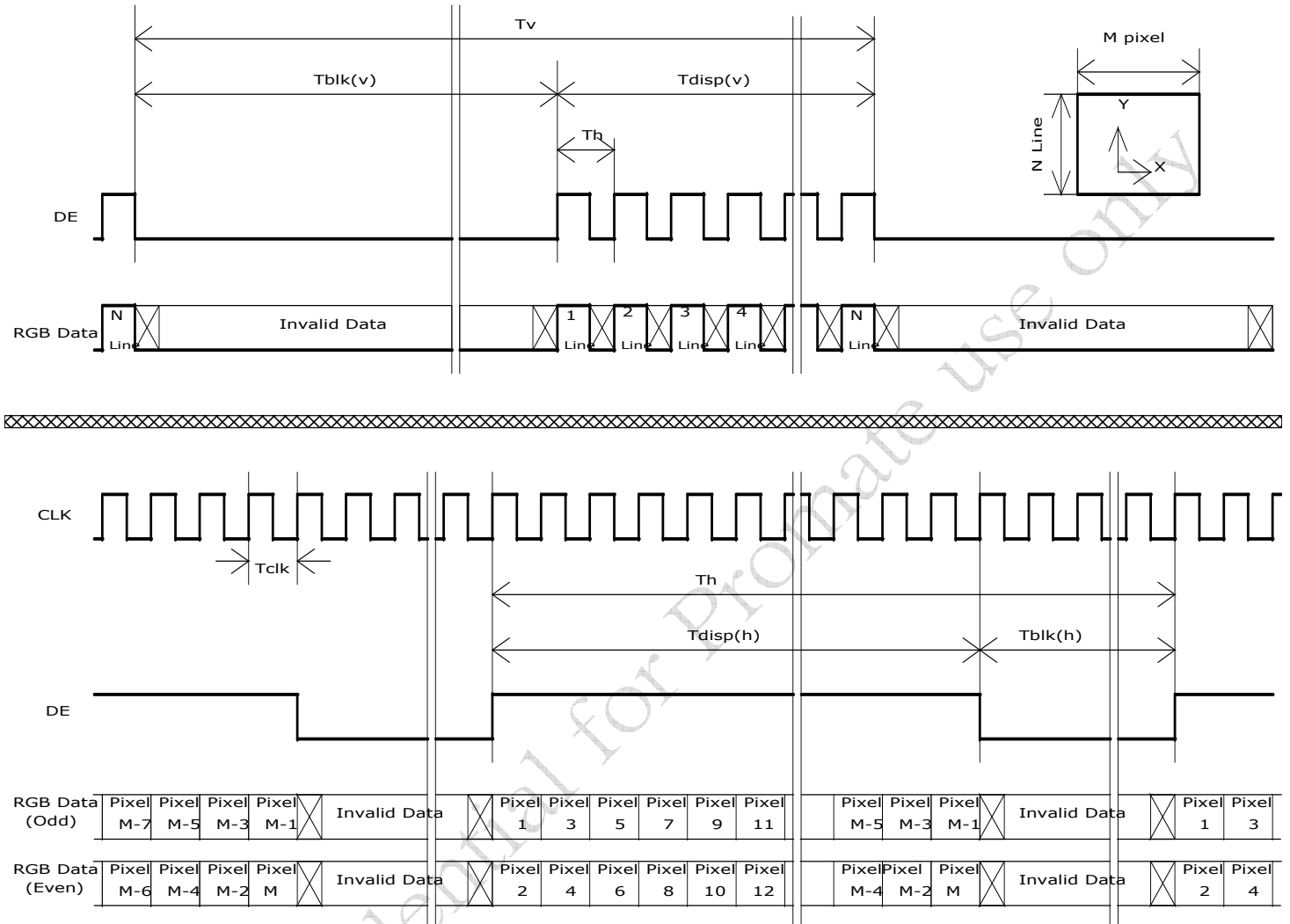

## 6.6 Power ON/OFF Sequence

VDD power and lamp on/off sequence are as follows. Interface signals are also shown in the chart. Signals from any system shall be Hi-Z state when VDD is off.

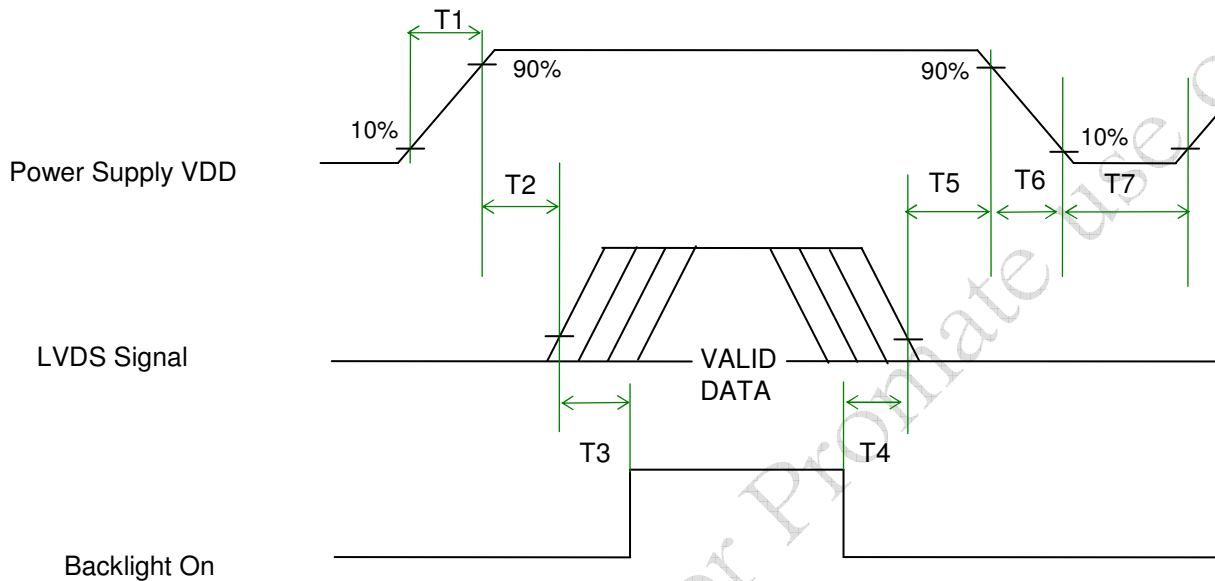

**Power Sequence Timing**

Parameter	Value			Unit
	Min.	Typ.	Max.	
T1	0.5	-	10	[ms]
T2	0	-	50	[ms]
T3	500	-	-	[ms]
T4	100	-	-	[ms]
T5	0	-	50	[ms] Note 1,2
T6	5	-	100	[ms] Note 1,2
T7	1000	-	-	[ms]

**Note 1 :** Recommend setting T5 = 0ms to avoid electronic noise when VDD is off.

**Note 2 :** During T5 and T6 period , please keep the level of input LVDS signals with Hi-Z state.

## 7 Connector and Pin Assignment

Physical interface is described as for the connector on module. These connectors are capable of accommodating the following signals and will be following components.

### 7.1 TFT LCD Module

Connector Name / Designation	Interface Connector / Interface Card
Manufacturer	P-TWO / STM
Type Part Number	187034-30091 / MSBKT2407P30HB
Mating Housing Part Number	FI-X30HL (Locked Type)

#### 7.1.1 Pin Assignment

Pin#	Signal Name	Pin#	Signal Name
1	RxOIN0-	2	RxOIN0+
3	RxOIN1-	4	RxOIN1+
5	RxOIN2-	6	RxOIN2+
7	GND	8	RxOCLKIN-
9	RxOCLKIN+	10	RxOIN3-
11	RxOIN3+	12	RxEIN0-
13	RxEIN0+	14	GND
15	RxEIN1-	16	RxEIN1+
17	GND	18	RxEIN2-
19	RxEIN2+	20	RxECLKIN-
21	RxECLKIN+	22	RxEIN3-
23	RxEIN3+	24	GND
25	NC (for AUO test only. Do not connect)	26	NC (for AUO test only. Do not connect)
27	NC (for AUO test only. Do not connect)	28	VDD
29	VDD	30	VDD

## 7.2 LED Connector on Backlight Unit

This connector is mounted on LED light bar.

Connector Name / Designation	Light Bar Connector
Manufacturer	ENTERY INDUSTRIAL CO., LTD.
Type Part Number	3707K-S06N-21R
Mating Housing Part Number	H112K-P06N-13B (Locked Type)

### 7.2.1 LED Pin assignment

Pin#	Signal Name
1	IRLED1 (current out)
2	IRLED2 (current out)
3	VLED (voltage in)
4	VLED (voltage in)
5	IRLED3 (current out)
6	IRLED4 (current out)

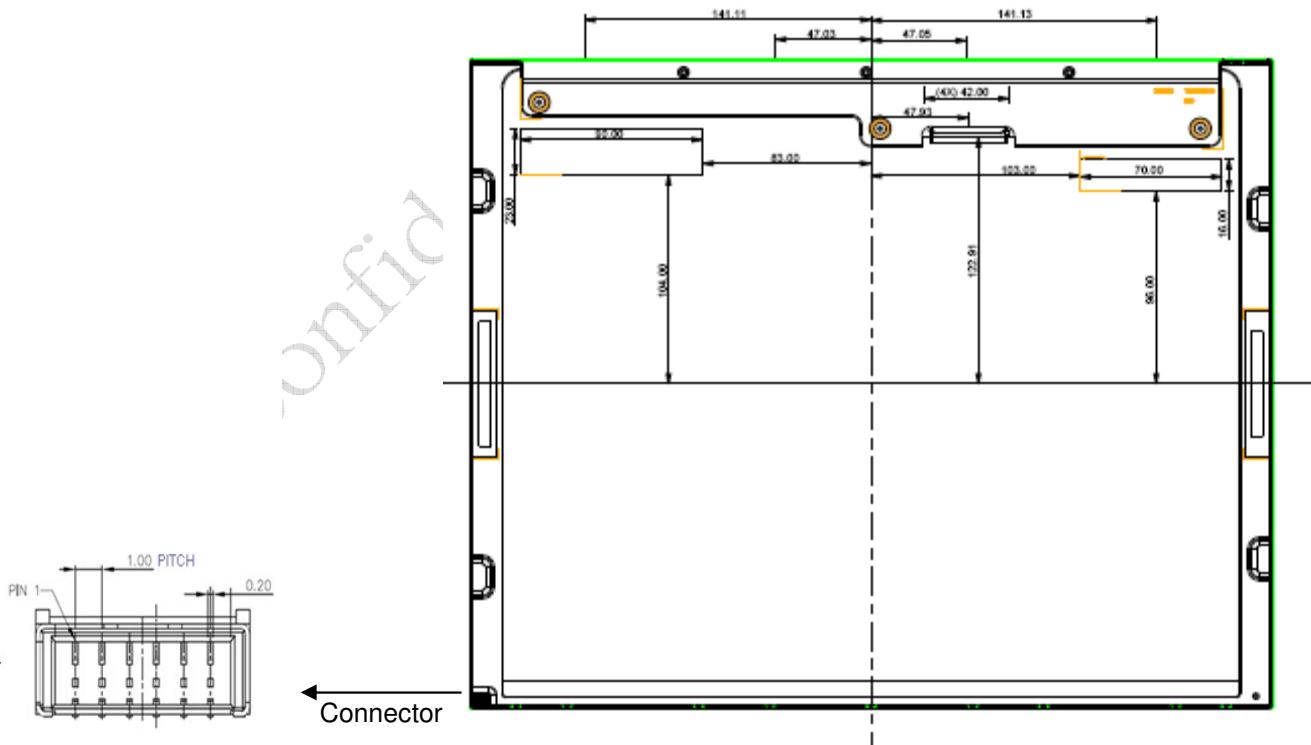

## 7.2.2 LED Connector Dimension

$H \times V \times D = 13.9 \times 3.00 \times 4.25$ , Pitch = 1.0 (unit = mm)

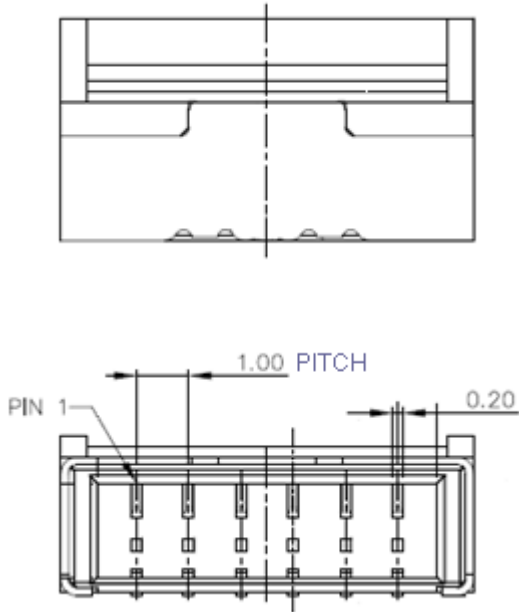

## 7.2.3 LED Mating housing dimension

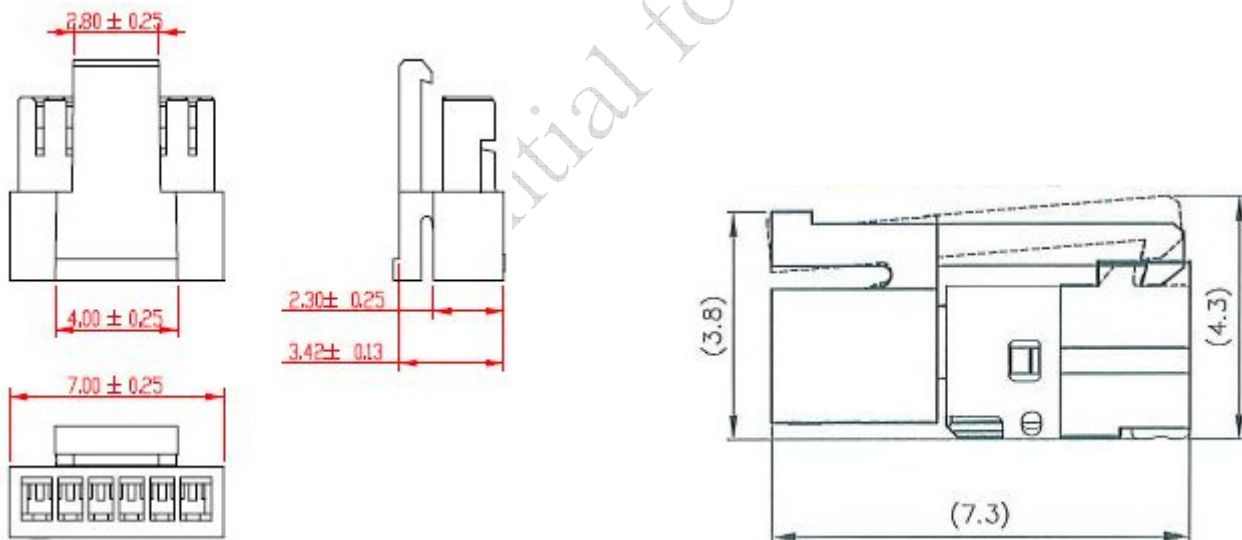

## 8 Reliability Test

Environment test conditions are listed as following table.

Items	Required Condition	Note
Temperature Humidity Bias (THB)	Ta= 50°C, 80%RH, 300 hours	
High Temperature Operation (HTO)	Ta= 50°C, 50%RH, 300 hours	
Low Temperature Operation (LTO)	Ta= 0°C, 300 hours	
High Temperature Storage (HTS)	Ta= 60°C, 300 hours	
Low Temperature Storage (LTS)	Ta= -20°C, 300 hours	
Vibration Test (Non-operation)	Acceleration: 1.5 Grms Wave: Random Frequency: 10 - 200 Hz Duration: 30 Minutes each Axis (X, Y, Z)	
Shock Test (Non-operation)	Acceleration: 50 G Wave: Half-sine Active Time: 20 ms Direction: ±X, ±Y, ±Z (one time for each Axis)	
Drop Test	Height: 46 cm, package test	
Thermal Shock Test (TST)	-20°C/30min, 60°C/30min, 100 cycles	<b>Note 1</b>
On/Off Test	On/10sec, Off/10sec, 30,000 cycles	
ESD (Electro Static Discharge)	Contact Discharge: ± 15KV, 150pF(330Ω ) 1sec, 15 points, 25 times/ point	<b>Note 2</b>
	Air Discharge: ± 15KV, 150pF(330Ω ) 1sec 15 points, 25 times/ point	
Altitude Test	Operation: 18,000 ft Non-Operation: 40,000 ft	

**Note 1:** The TFT-LCD module will not sustain damage after being subjected to 100 cycles of rapid temperature change. A cycle of rapid temperature change consists of varying the temperature from -20°C to 60°C, and back again. Power is not applied during the test. After temperature cycling, the unit is placed in normal room ambient for at least 4 hours before power on.

**Note 2:** EN61000-4-2, ESD class B: Certain performance degradation allowed:

- No data lost
- Self-recoverable
- No hardware failures





# Product Specification

M190ETN01.0

AU OPTRONICS CORPORATION

AUO confidential for Promate use only

## 9 Shipping Label

The label on the panel is shown as below:

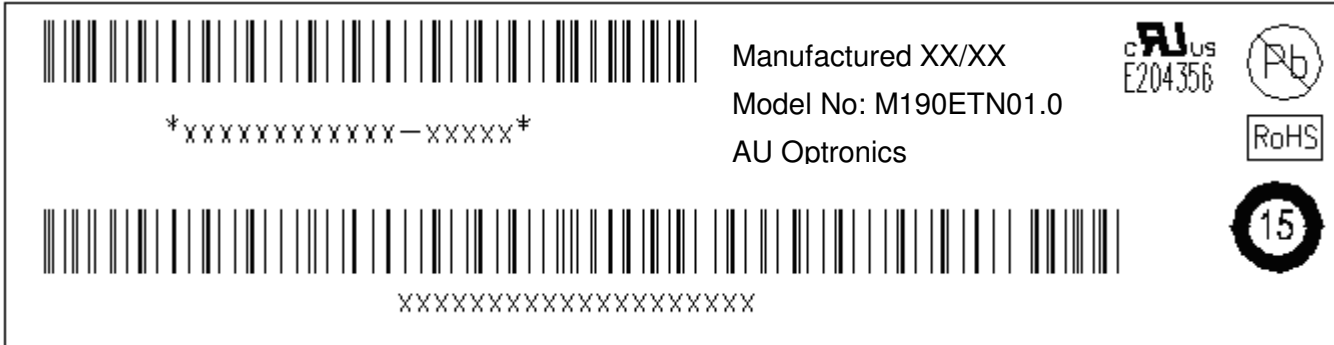

**Note 1:** For Pb Free products, AUO will add  for identification.

**Note 2:** For RoHS compatible products, AUO will add  for identification.

**Note 3:** For China RoHS compatible products, AUO will add  for identification.

**Note 4:** The Green Mark will be presented only when the green documents have been ready by AUO Internal Green Team.

## 10 Mechanical Characteristics

**Avoid touching COF position when doing mechanical design**

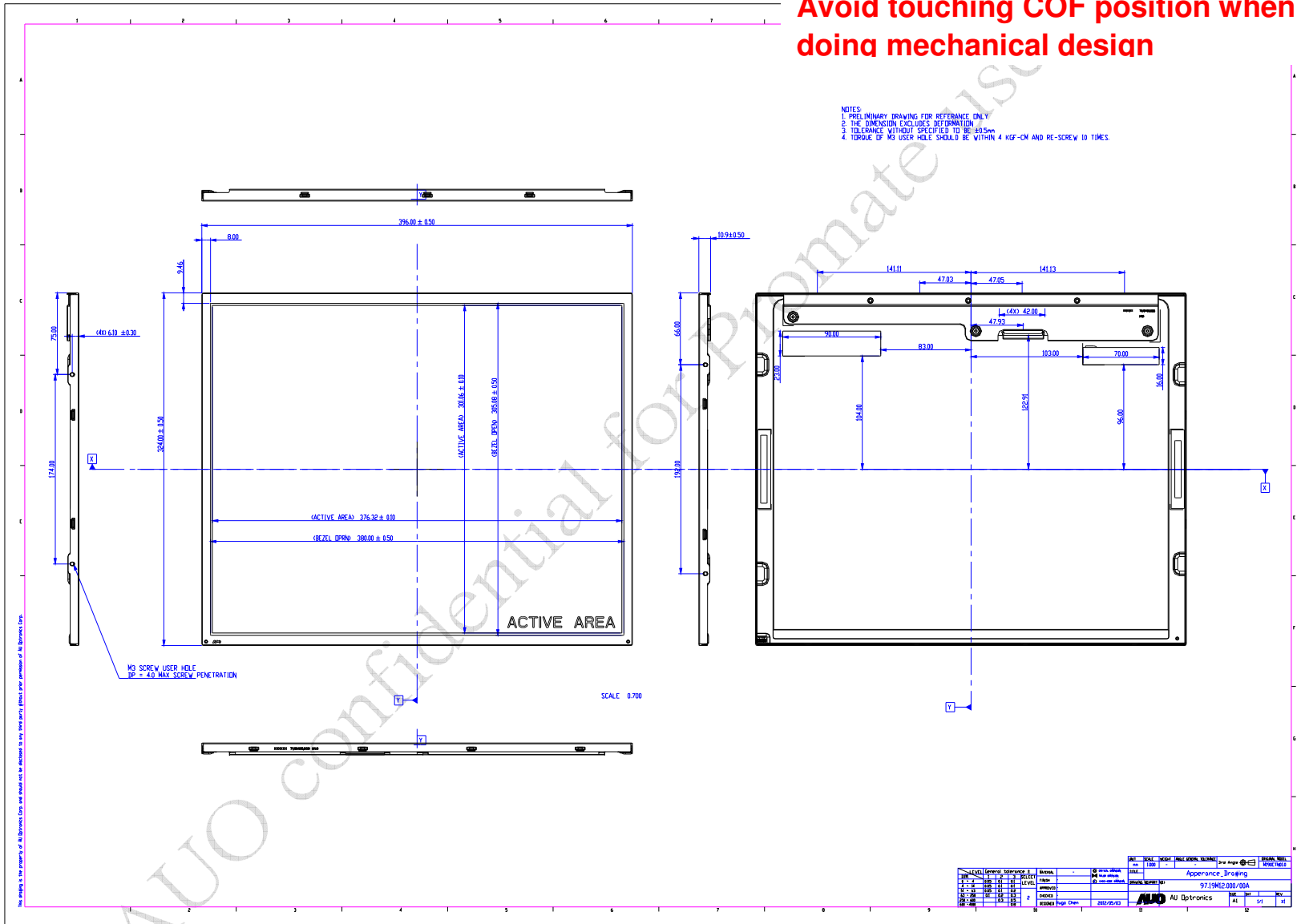

## 11 Packing Specification

### 11.1 Packing Flow

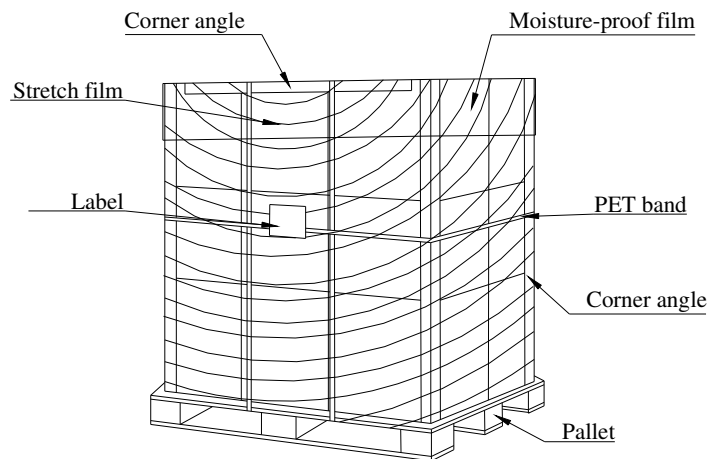
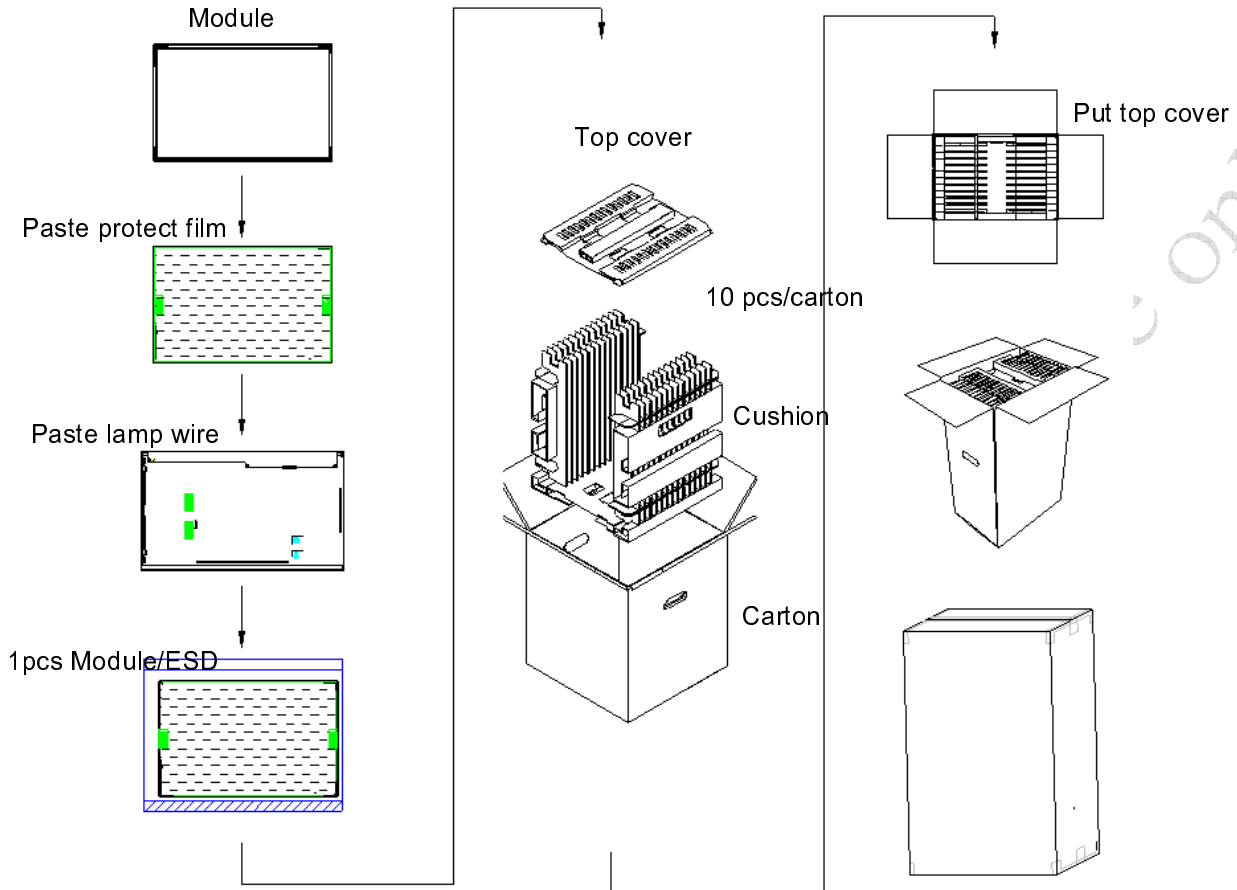

## 11.2 Pallet and Shipment Information

	Item	Specification			Remark
		Q'ty	Dimension	Weight(kg)	
1	Panel	1	396(H)mm x 324(V)mm x 10.9(D)mm	1.8	<b>Note 1</b>
2	Cushion	1	--	1.85	
3	Box	1	409(L)mm x 367(W)mm x 475(H)mm	1.44	without Panel & cushion <b>Note 1</b>
4	Packing Box	13 pcs/Box	409(L)mm x 367(W)mm x 475(H)mm	26.83	with panel & cushion <b>Note 1</b>
5	Pallet	1	1140(L)mm x 830(W)mm x 138(H)mm	12	<b>Note 1</b>
6	Pallet after Packing	18 boxes/pallet	1140(L)mm x 830(W)mm x 156.5(H)mm	492.42	<b>Note 1</b>

**Note 1:** Estimated value which is subject to change based on real measured data.